

Exhibit 13.2.a

**Schlumberger Carbon Services
Summary Results for Carbon Storage Feasibility Study**

**Summary Results for:
Carbon Storage Feasibility Study
Taylorville Energy Center (TEC)**



**Submitted to:
Christian County
Generation, L.L.C.**

**Date:
Revised February 23,
2010**

**Schlumberger Carbon
Services**
4449 Easton Way, 2nd Floor
Tel: 614-934 1019
Email: pjagucki@slb.com
www.slb.com/carbonservices

Project Summary and Findings

The Taylorville Energy Center (“TEC”) is being developed by Christian County Generation, L.L.C. (“CCG”). The project is proposed electric generation facility using an Integrated Gasification Combined-Cycle (“IGCC”) design. Located in Taylorville, Illinois, the plant’s anticipated commercial operation date is 2015. The feedstock for this plant is Illinois coal. A total of 3,410,000 metric tons of CO₂ per year could be captured, , from this plant.

A geological study was completed to develop an assessment of the suitability of the site for storage of carbon dioxide. The work is the first phase in developing a geologic carbon dioxide (CO₂) storage site in the Mt. Simon formation. The goal of the study was to evaluate:

1. Whether the site has capacity to store the expected volume of CO₂ from the plant;
2. Containment of the storage reservoir;
3. Infrastructure requirements for storage (number and dimensions of injection wells, operational strategies)

The results of the study indicate that the Mt. Simon sandstone has sufficient porosity (open space between the sand grains in the rock) and permeability (the degree to which the pore spaces are interconnected, allowing fluid to move through the rocks) and therefore provides a storage reservoir target capable of accommodating all of the CO₂ produced by the plant over a planned operational life of 30 years. The Eau Claire formation, which overlies the Mt. Simon sandstone, will provide the vertical containment needed to prevent movement of CO₂ out of the Mt. Simon formation and into shallower geologic formations, ground water, and the atmosphere. There are also several other low permeability layers that provide secondary containment. The Mt. Simon formation and the containment layers are laterally extensive and available information, including the results of a subsurface (seismic) survey, confirm that there are no faults or breaks in the lateral continuity of the formation. This provides further support that the CO₂ will remain in place.

The storage reservoir is situated over 5000 feet below the regional drinking water supplies. Other available studies and data from the area indicate that the reservoir is below all underground sources of drink water (USDWs) as defined by the US EPA.

The geologic data were developed into a computer model of the site. Operating options for the base case, assuming 3,410,000 metric tons of CO₂ per year, were then developed through an iterative process and flow simulations were created to identify general design considerations and the number of injection wells required, and also to predict the size and movement of the injected CO₂ plume. The modeling suggests that while a single injection well may have the capacity to handle the expected volume, a base case of three injection wells provides optimum modeled injection operations. The modeling indicates that no more than four wells would be needed, in consideration of

potential variations in site geologic conditions. The modeling also shows that the CO₂ would occupy approximately 20 square miles (2.5 miles by 8 miles) and that the plume stabilizes and remains in approximately the same position as it is at the time injection is complete. Following injection, pressures in the reservoir return to normal pressures, removing forces that could act to move the CO₂.

An alternate case considered 2,274,000 metric tons of CO₂ per year. Although this case was not modeled in detail, preliminary modeling and extrapolated study results suggest that two injection wells could be designed and optimized to handle this reduced volume. The CO₂ plume volume and area is also inferred to be proportionally reduced.

Other key findings of the study are that the CO₂ produced by the plant is over 98% pure CO₂ and would be compatible with the existing formation fluid (brine or saltwater that is at least several times saltier than sea water). The site meets the conditions for a permit application under the Underground Injection Control (UIC) regulations, which fulfill requirements of the Safe Drinking Water Act and are administered by the Illinois EPA.

Site Description and Study Objectives

The project area is located just north of Taylorville (pop. 11,427), and approximately 30 miles to the southwest of Decatur (pop. 109,309). The area is predominantly used for agriculture and its flat terrain is held mostly by private landowners for growing crops. Sparse oilfield infrastructure is present. Access to the area is from State Hwy 48 or 29, Figure 1. Gravel and paved roads exist within the project area.

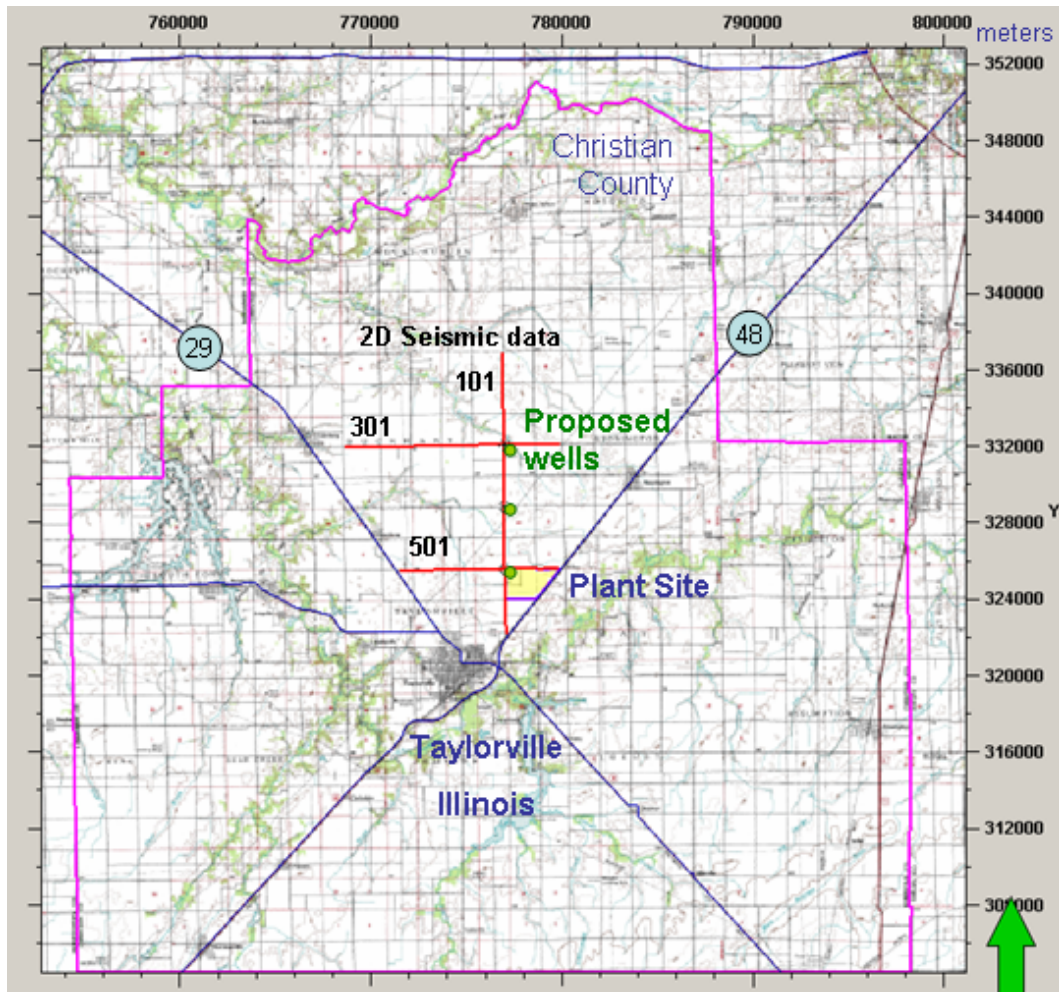

Figure 1. Topographic map of the 30x30 mile study area. The proposed plant site is located a little over two miles northeast of Taylorville Illinois along State Route 48. Located in Christian County, north of Taylorville, three proposed injection wells are shown here adjacent to three 2D seismic lines that were acquired in July 2009.

One option under consideration for managing CO₂ from the facility is to compress it and sell it to a CO₂ pipeline operator. The pipeline would ship it off site for enhanced oil recovery (EOR). Deep saline (geologic) storage capability is needed for alternate or supplemental storage in the event that efforts to develop a CO₂ pipeline are delayed or are unsuccessful. The geological storage site may be required to assure that geologic storage is available to the TEC. The Mt. Simon storage field will be dedicated exclusively to the TEC.

CO₂ will likely be injected pursuant to proposed EPA Class VI geological storage well regulations. However, because the regulations may not be finalized until 2011, the injection wells initially will be permitted using existing nonhazardous Class I well regulations and guidance.

The geologic storage feasibility study includes: a review of the properties in the Mt. Simon formation in the area of the TEC site; development of a predictive model for a CO₂ storage field in the Mt. Simon formation; a determination of storage targets; an initial seismic survey of the area; a proposed well design; and an estimate of the cost to develop a storage field for TEC.

The Mt. Simon formation is at a depth of approximately 5615 feet, has a thickness of 1100 to 1500 feet, and is confined by well over 200 feet of low permeability shale (the Eau Claire formation). The depth of the storage reservoir and the presence of sealing caprock provide secure storage and containment. Based on the current study, the storage reservoir has more than sufficient capacity to handle CO₂ produced through the life of the facility.

A 21 mile 2D seismic survey of the area was completed. The seismic data along with the properties of Mt. Simon formation were used to create a 30x30 mile reservoir model to estimate potential injection capacity. This will be revised once additional site-specific subsurface data are available. The seismic survey showed that there is good lateral continuity of the storage reservoir and containment layers. No faults or displacement (shifting) of the layers was indicated in the survey. This provides further evidence that the reservoir and caprock will provide secure containment.

Pertinent information gathered and reviewed for the evaluation includes:

- Preliminary depth, thickness, porosity, permeability and temperature of the Mt. Simon formation and the vertical confinement properties of the Eau Claire formation (primary containment) and other shallower formations (secondary containment)
- 2D seismic survey of the area (21 miles)
- Reservoir model
- Preliminary well design (including schematic)
- Preliminary well model and estimated well performance
- Estimated plume size
- Estimated injection and observation well spacing
- North-South and East-West cross sections showing injection zones, vertical confinement thicknesses and identification of the lowest fresh water reservoir
- Map showing faults, wells that penetrate the Mt Simon and vertical confinement layers; major roads, major towns, depleted, abandoned, and currently producing oil and/or gas fields, and known mine workings in the area
- Estimated base, maximum, and minimum injection rates; pressures; and CO₂ plume size for 30 years of injection
- Potential locations for the storage field

Site characteristics

There is relatively little topographical relief in the study area. Within a 12-mile radius of the proposed site, the average elevation is 600 feet with a standard deviation of 18.5

feet. The hydrographic features in the area consist of natural and manmade drainage and streams that flow predominately in the northwest direction. The land use in the area is largely agricultural with row crops and pasture. There are 14 incorporated areas that have commercial and residential land uses including Taylorville.

The relevant near-surface and subsurface features in and around the proposed site include shallow aquifers, mineral resources, and mines. There are shallow glacial and alluvial aquifers in the area that act as a water source [Midwest Technology Assistance Center 2009A and 2009B]. However, these mapped features are not coincident with the proposed injection site. Although most groundwater in the area is withdrawn from shallow unconsolidated formations, the St. Peter formation could be the deepest underground source of drinking water (USDW) as defined by US EPA. The injection reservoir is below the St. Peter sandstone. The formations are separated by the Eau Claire shale, which will provide vertical containment of the CO₂.

The local surface strata are Pennsylvanian in age, and consist of interbedded shale, sandstone, limestone, and coal seams. From the TEC site, the Pennsylvanian rock has a subtle dip to the southeast into the Illinois Basin.

Coal is prevalent throughout Pennsylvanian-age strata in Illinois. The most notable seam in the area is the Herrin coal, which is prevalent in Christian County. The Herrin coal has been mined mostly in the south, southwest, and east of the proposed injection wells (Figure 2). Local to the proposed injection wells this coal seam is over five feet thick and occurs at a depth of 400 to 500 feet below ground level.

An inventory of wells in the area include appraisal wells, oil and gas production wells, gas storage wells, water production wells, and water injection wells. Public records show that there are 1504 water production wells, 191 water disposal wells, 191 confidential wells, and 2807 other (oil, gas related, and others) wells within a 12-mile radius of the proposed injection area (see Figure 2). Only 4 wells in the vicinity of the site penetrated the St. Peter formation; three of those wells are now abandoned. The maximum total depth of the deepest of these wells is 3252 feet (a salt water injection well). There are no gas storage fields in the 30 x 30-mile study area. The closest gas storage field is the Hillsboro field, which is approximately 27 miles SW of the proposed storage site and injects into the St Peter formation.

References

Midwest Technology Assistance Center, 2009A, "Groundwater Resource Assessment for Small Communities: Groundwater Availability at Morrisonville, Illinois (Christian County), <http://mtac.isws.illinois.edu/gwassmnts.asp>

Midwest Technology Assistance Center, 2009B, "Groundwater Resource Assessment for Small Communities: Groundwater Availability at Morrisonville, Illinois (Christian County), <http://mtac.isws.illinois.edu/gwassmnts.asp>

Coal Mines





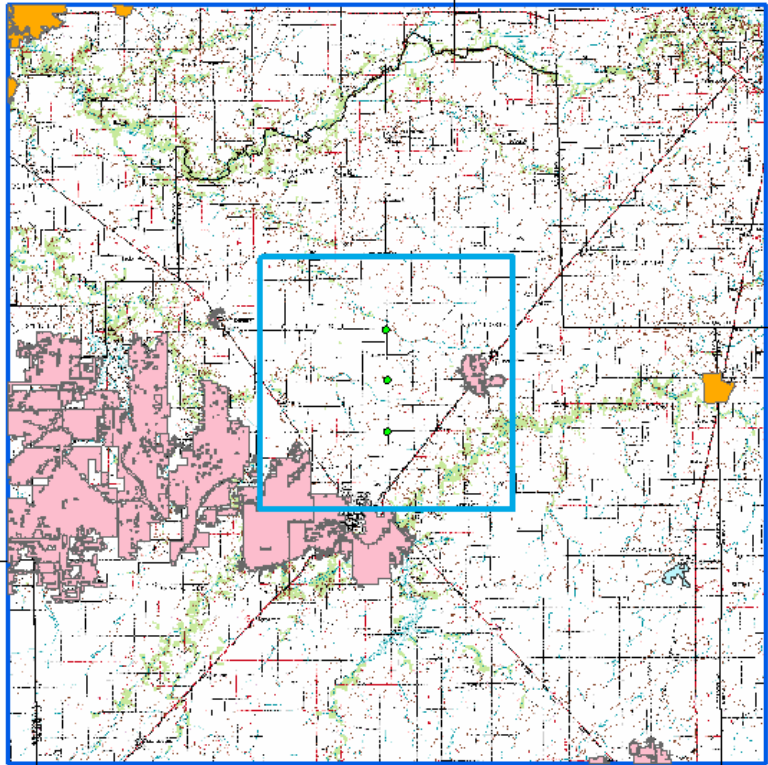





LEGEND

-  Herrin Coal Mine
-  Springfield Coal Mine
-  Assumption Coal Mine
-  30-Mile AOI
-  10-Mile AOI



Well Inventory

LEGEND

-  10 x 10 mile study area
-  30 x 30 mile study area
-  Highway
-  Christian County Line
-  Water well
-  Plugged well
-  Oil well
-  Confidential well
-  Coal test well
-  Other well
-  Proposed injection well

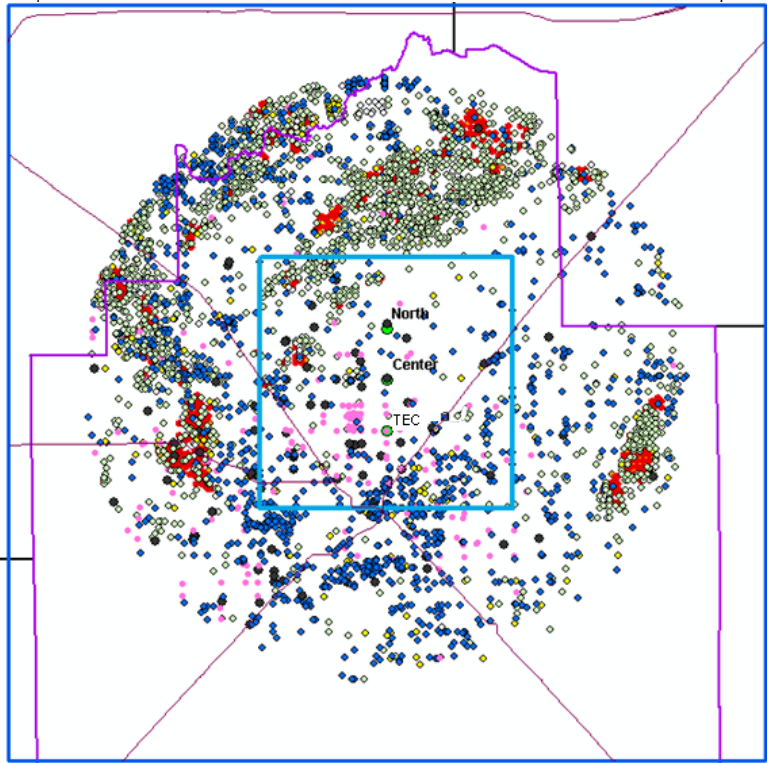

Figure 2. Near-surface features in the study area include coal mines and wells. The Herrin Coal seam exists throughout Cristian County and has been mined locally. An inventory of wells in a 12-mile radius of the proposed Center well reveals the presence of some hydrocarbons. These resources are relatively small, and more importantly, shallower than the intended CO₂ storage interval.

Seismic Acquisition, Processing, Interpretation, and Development of Site Geological Model

WesternGeco conducted a local 2D survey over the proposed TEC site to provide data to evaluate if the subsurface formations were suitable for carbon storage. The survey included a total of approximately 21 miles of data acquired. The specific formations of interest are the Eau Claire at ~5,151 – 5,615 feet (a caprock) and the Mount Simon Sandstone at ~5,615 – 6,915 feet (the storage reservoir). The survey also provided an assessment of the lateral continuity of the formations of interest and whether there were any faults or displacement of the formations that could create weakness in the reservoir containment.

County road permits were secured for the 2D seismic survey. At the time of the survey (July 2009), contact was made with neighbors to inform them of the activity and to answer questions regarding the survey. WesternGeco, along with subcontractors (Survey Technology Inc, Conquest Seismic Services and VibraTech Monitoring Services) deployed survey markers, geophone strings, three truck-mounted vibrators, and the advanced system for acquisition and processing of seismic data. The acquisition of surface 2D seismic data (a total of 21 miles), its quality control, and processing was performed by the contractor. Processing was performed using WesternGeco's OMEGA software.

The crew successfully concluded this project, using the advanced recording system while fully complying with Schlumberger's Quality, Health, Safety and Environment (QHSE) Management System (MS) and complying with TEC's project requirements.

The final product was three enhanced 2D seismic lines. The data consisted of one N-S trending 2D seismic line (L101) and two E-W lines L301 and 501 (Figures 1 and 3). This data was loaded into Schlumberger's Petrel software for interpreting subsurface data and preparing geological models. The model also included three proposed injection wells at a surface elevation of 612 feet placed 2 miles apart trending north from the plant site, Figures 3 and 4.

Geologic Interpretation

The Eau Claire shale can exist as a broad regional feature and was easy to distinguish in the seismic data from the overlying, dolomitic Knox Formation, Figure 3B. Shale is a fine grained rock that has low permeability (allows very limited vertical movement of fluids) and so provides an excellent primary seal to the Mt. Simon storage reservoir. The Mt. Simon is a sandstone formation, understood to have been deposited in a fluvial (river) setting. The sedimentary structures associated with the braided features of the river introduce some heterogeneity (variability) into this rock unit. The seismic survey verified the Eau Claire and Mt. Simon are laterally extensive through the study area. Synthetic seismograms were also developed based on other regional data. Synthetic logs were used to help verify the interpretation of the geologic model.

Studying the 2D seismic data, no discernible faults dissecting the Paleozoic section were apparent. The reservoir model, consisting of horizons interpreted from the seismic, dips to the southeast by no more than one degree. This represents a very gentle dip.

So although the CO₂ will be less dense than the existing brine (and so would be buoyant) the dip is so low that movement of the CO₂ will not be enhanced or accelerated due to the dip of the storage reservoir.

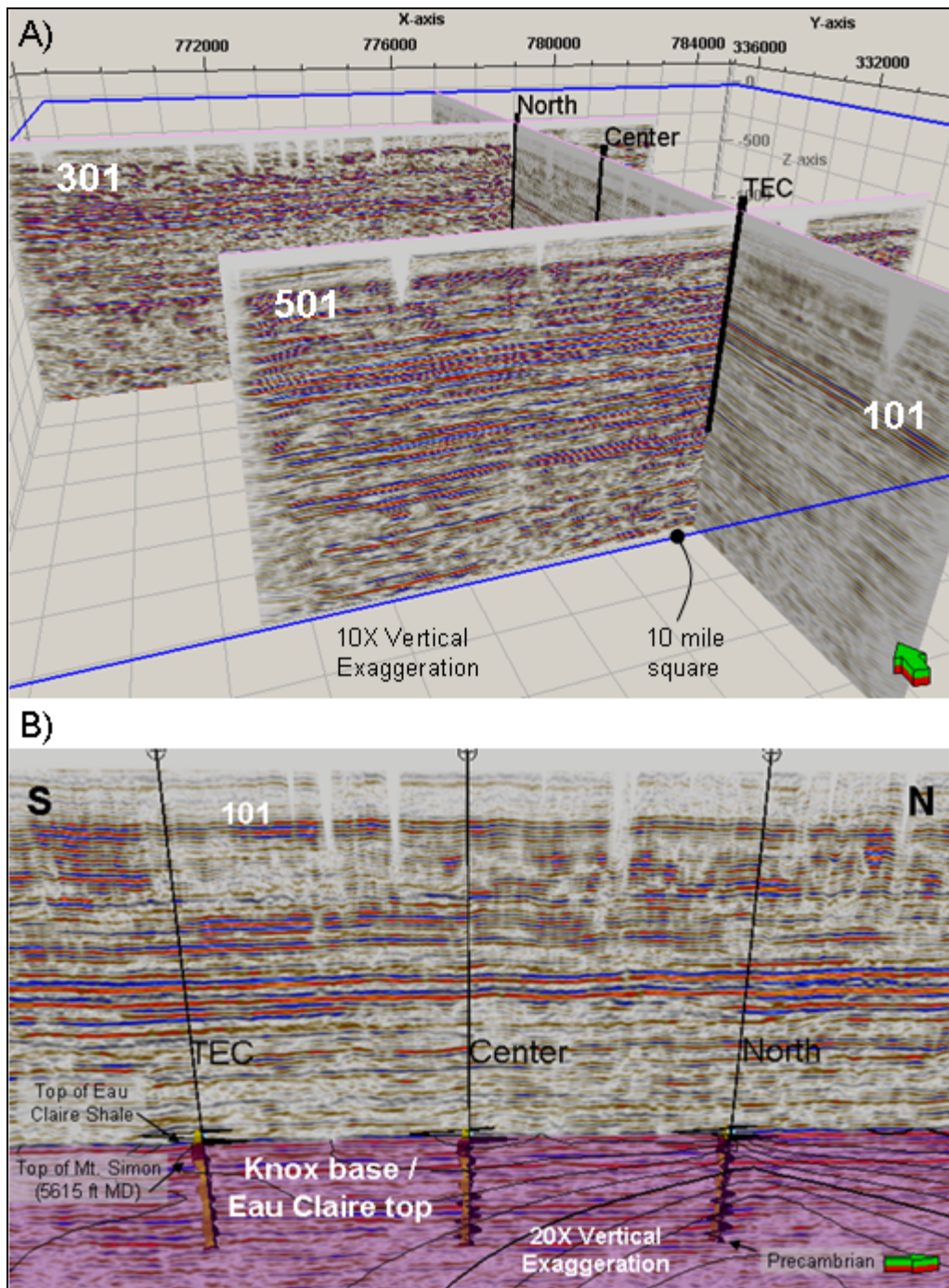

Figure 3. The three 2D seismic lines are shown here adjacent to the three proposed injection wells. A) The three proposed injection wells are placed 2 miles apart. The blue line represents a square with 10-mile-sides centered on the proposed “Center” well. B) Gamma ray logs and synthetic seismograms based on sonic logs are used to interpret the contact between the base of the Knox dolomite and the Eau Claire shale. The Mt. Simon is deeper at 5615 feet.

A 30 by 30 mile area of interest was selected for this project, largely to enable the reservoir engineers to model subtle pressure changes at a distance from the TEC injection site (see Figure 4).

In summary, an interpretation of 2D seismic data at the site revealed the gentle stratigraphic dip present in the area that strikes to the southeast and dips by less than 1 degree. The seismic information shows relatively uniform bedding for the reservoir of interest, the caprock, and shallower formations. Subtle sedimentary features were noted in the Mt. Simon. However, given our understanding that this formation consists of a braided fluvial system, these sorts of variations are to be expected. The seismic lines did not reveal the presence of faulting.

The Mt. Simon rests on an interval referred to as the “Granite wash”, which is considered the weathered and reworked materials from the underlying, granitic, Precambrian basement rock. Few wells penetrate the Granite wash; it is believed that this zone is well cemented and offers very little opportunity for carbon storage.

The Midwest Geological Sequestration Consortium (MGSC) has prepared a regional map of the Mt. Simon based on well data. At the TEC site that anticipated depth is ~5615 feet from ground level to the top of the formation; the expected thickness is somewhere between 1100 to 1300 feet, placing the bottom of the reservoir at about 6800 feet below ground surface.

The Mt. Simon has many intervals consisting of relatively clean sand with abundant pore space between its grains. The many Mt. Simon layers shown in Figure 4 represent variations in the formation’s permeability, a key property to consider when modeling a storage reservoir. The overlying Eau Claire consists of much finer particles like silt and clay. These materials compact very tightly, have limited porosity, and have even more limited vertical permeability.

Above the Eau Claire there is approximately 1500 feet of the Knox Supergroup that is largely characterized by the presence of dolostone (which also typically has low primary permeability). Above this is ~180 feet of the St. Peter Sandstone which is also known for its reservoir properties. The water-bearing St. Peter has good pore space too, and in some areas in Illinois it is used for the storage of natural gas and has been used historically for disposal of oil-field brine wastes. The St. Peter is overlain by Ordovician dolostone followed by a potential secondary cap rock, the Maquoketa Shale which is approximately 200 feet thick. Above this is more dolostone of Silurian and Devonian age.

At the transition of the Devonian and Mississippian age rock formations is the regionally known New Albany Shale, which is another layer of containment between the storage reservoir and the shallow drinking water supplies. It has a thickness of approximately 125 feet. At approximately 2100 feet down from ground level, this shale unit is a favorable secondary seal. Above the New Albany are alternating units of Mississippian limestone and sandstone. These intervals have some oil reservoirs. Moving upward into the Pennsylvanian there are numerous coal seams. These coal seams alternate with intervals of sandstone, shale, and limestone. Some of the shallow coal seams have been mined locally.

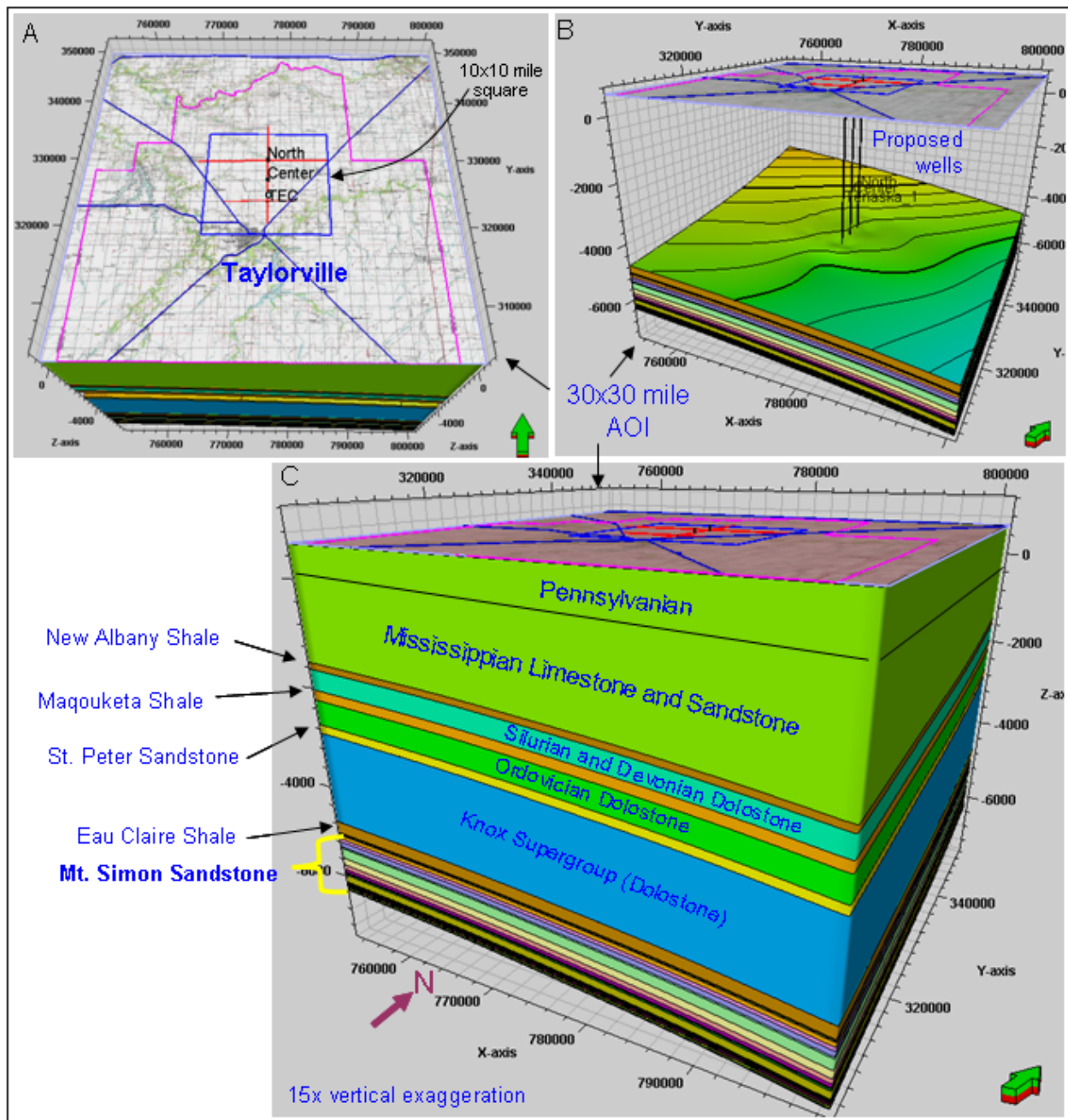

Figure 4. Geological model for a 30x30 mile Area of Interest (AOI) around the TEC site. The reservoir model consists of 27 Mt. Simon zones and 264 layers. The initial model consists of 6.7 million cells that are 300 meters square. A) Oblique map view of the proposed TEC wells north of Taylorville, Illinois. B) Cut-away view of the model showing the proposed wells penetrating the top of the Eau Claire Shale. Based on 2D seismic data, the strata dips to the southeast by less than one degree. C) Layer cake geological model illustrating some of the key reservoirs and seals within the Area of Interest. Note the dip to the southeast. The Mt. Simon portion of the model is refined with many layers to realistically represent the natural petrophysical variations in the formation.

Pipeline and Reservoir Simulations

Pipeline and reservoir simulations were completed for the site through an iterative process to develop various injection scenarios and cases. This process allows for examination of a variety of conceptual designs. From this, the project team established a “base case” scenario and then alternate cases.

The pipeline and well sizing calculations were performed using PIPESIM 2009 (a steady-state, multiphase flow simulator used for the design and diagnostic analysis of oil and gas production systems and injection).

PIPESIM was used to simulate the various scenarios to choose the maximum number of wells needed to inject 239 lbs/s of CO₂ without exceeding 2,200 psia at the compressor. Parameters considered in the pipe simulations include: the gas composition, compressor operating pressure, temperature, distances between the wells, operating scenarios, and the internal diameters of the surface pipelines, injection pipe size, the geothermal gradient, trajectory and depths of the wells. A schematic of the injection wells and pipe network is shown in Figure 5.

The simulation also investigated two different fluid compositions. One composition was pure (100%) CO₂ and the other composition was specified 98.4% CO₂ and accounted for the CO₂ that would actually be generated at the facility.

Based on the results of the simulations the following conditions were established for the modeling:

- The Injection rates will be equally divided between all wells for both fluid composition scenarios. The tubing is sized to prevent erosion of the tubing by the CO₂.
- All 7-inch scenarios using three injection wells met the erosional velocity criterion with erosional velocity ratios less than one.
- If four wells are used, 5.5” may be used with a maximum permissible injection rate per well of 84 lbs/s at 120 F. Gas temperatures less than 120 F would allow for higher flows.

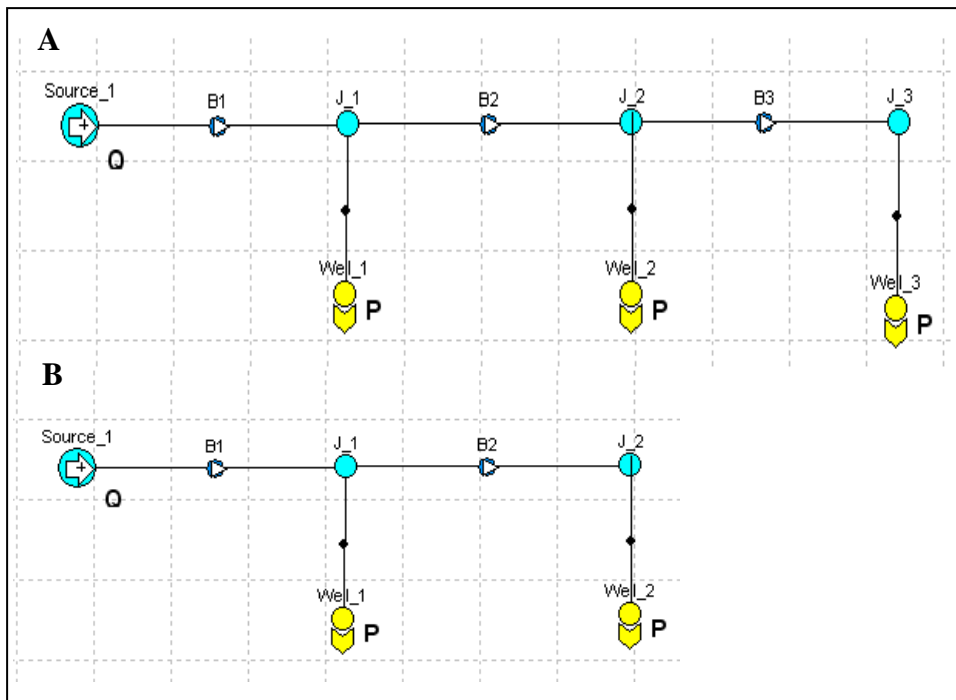

Figure 5. Pipeline networks for the 5.5-inch (A) and 7-inch (B) injection wells used in the PIPESIM modeling.

After the initial simulations (1 through 8) were completed 5 additional simulations were conducted using a network with 3 wells with 7-inch tubing.

Schlumberger worked with the reservoir model and the results of the pipe simulations in preparing a number of injection cases. These cases considered different pipe sizes, injection rates, two and three wells, plus a number of reservoir conditions.

The reservoir modeling results focused on a base case of injection through three wells and serves as a baseline to compare other cases which incorporate uncertainties in reservoir properties and alternative development strategies. This case is the best estimate of reservoir and surface parameters which are reiterated here.

- Geological model based on seismic and analog well data
- Injection start date of January 1, 2010
- Injection end date of January 1, 2040
- Simulation end date of January 1, 2140
- Fracture gradient of 0.65 psi/ft
- Injection rate of 80,000 lbs/s of CO₂
- THP of 2,100 psi for each well
- Source pressure of 2,220 psi

Given the current model, the full capacity of the forecasted field CO₂ injection can be covered by three wells given the imposed bottom of hole pressure (BHP) and top of hole pressure (THP) limits of the 0.65 psi/ft fracture gradient. The pressure response to the CO₂ injection is shown in Figure 6. The reservoir is cut north to south along injection wells to observe the maximum response in the model. For each date the change in pressure is shown relative to the start date of the simulation (January 2010).

It can be seen that reservoir pressure increases from initial conditions during the injection period but falls off to near initial pressure conditions by the end of the 100 year study period. The areal extent of the pressure response is contained within the model area.

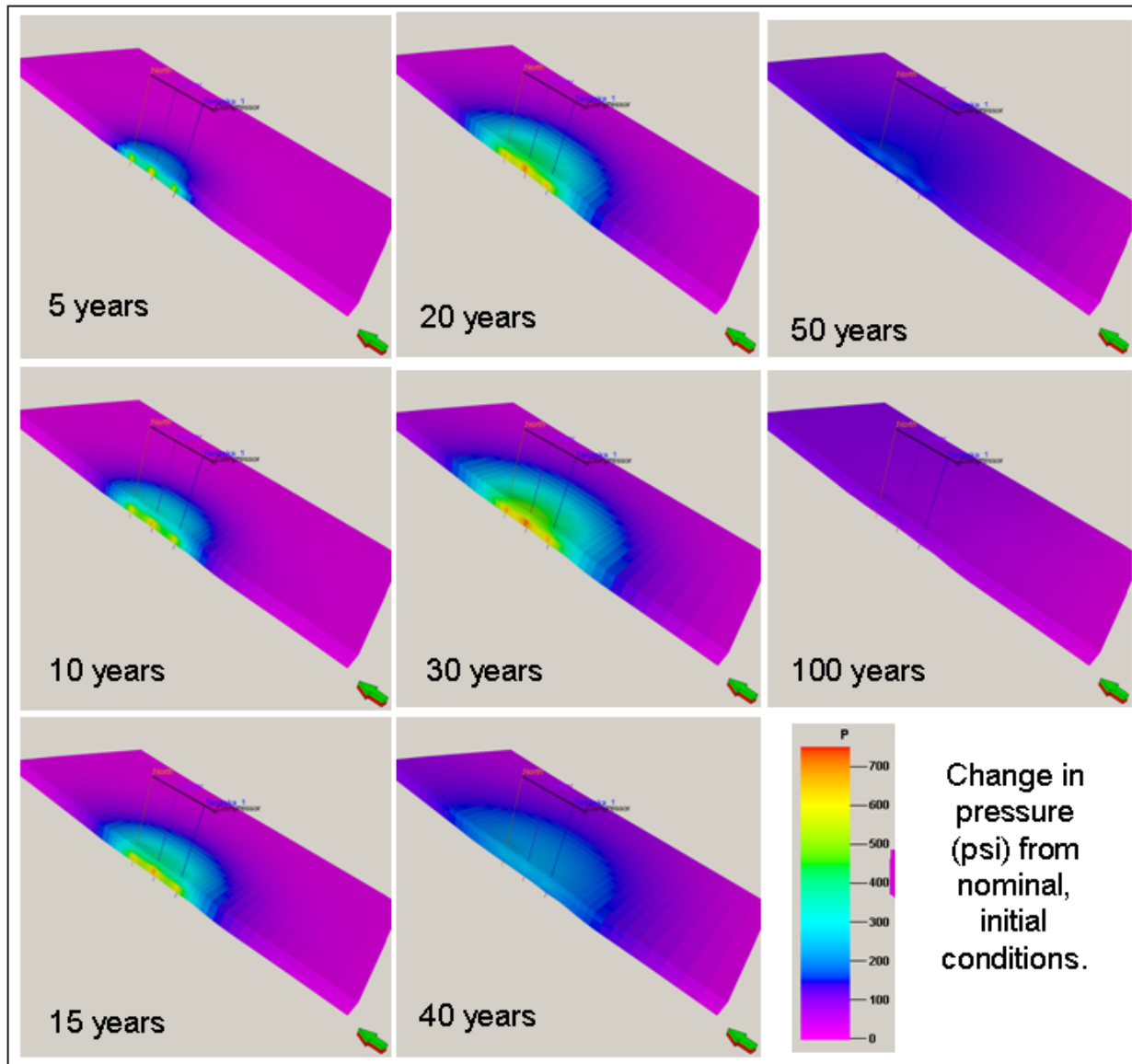

Figure 6. Oblique, cut-away view of the Mt. Simon reservoir model showing the three injection wells and changes in reservoir pressure through time. Change in reservoir pressure is shown relative to the start date of the simulation of January 2010. After the 30 years of injection, the pressure begins to declines back to initial conditions.

As CO₂ is injected into the formation, a plume develops and the areal extent must be estimated both during the injection period and for a specified period (in this case 100 years) following the injection period. The extent will be largely dependent on the distribution of porosity and permeability in the model. As each layer is given constant properties for both permeability and porosity, it is expected that this model will be optimistic in the predicted injection volumes. However, without additional information, this is the best estimate that can be obtained.

Figure 7 shows the development of the CO₂ plume through time where it reaches a maximum total length of 8.2 miles from north to south. It is interesting to note that the plume size does not change significantly with time after CO₂ injection is stopped.

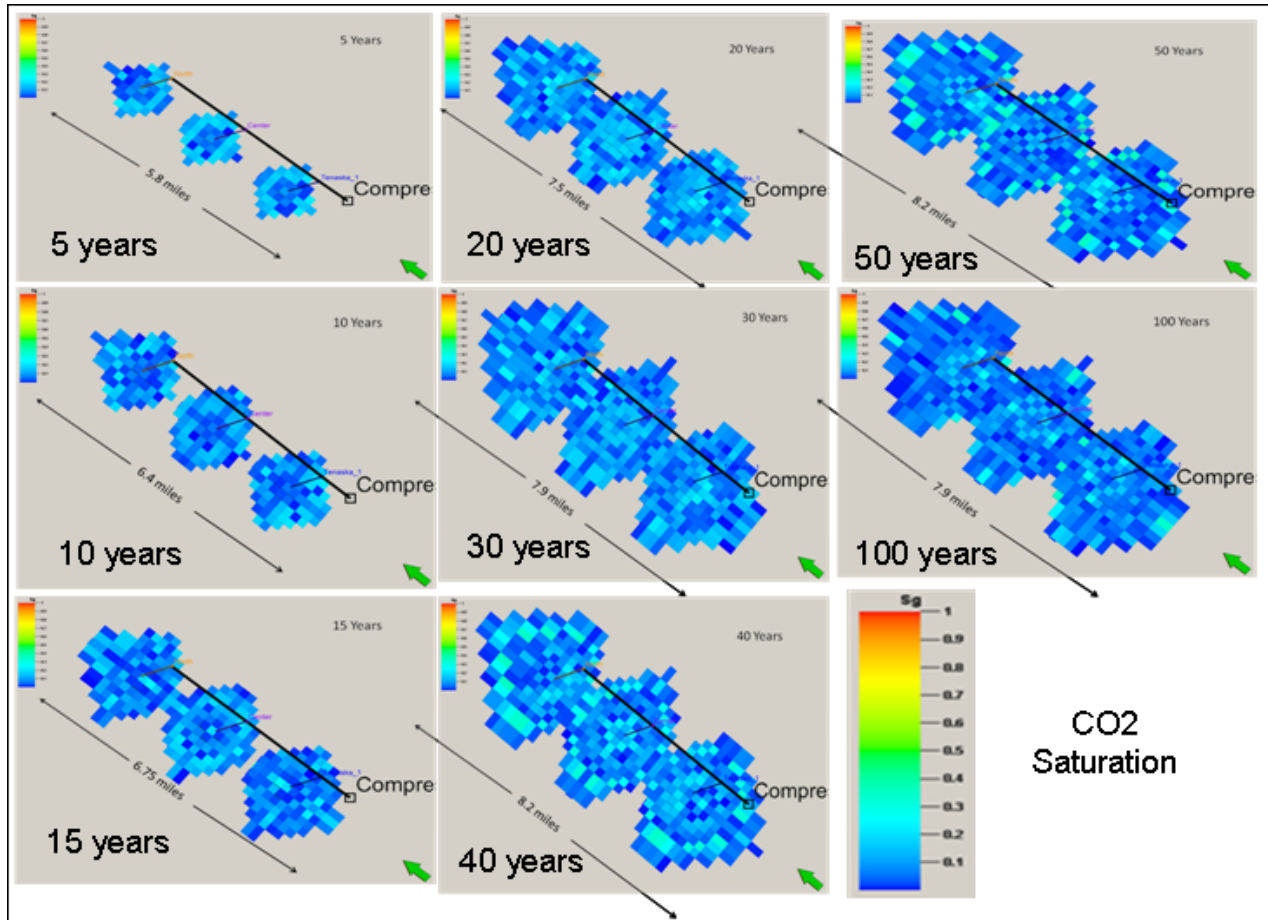

Figure 7. Areal view showing CO₂ plume migration. At the end of 30 years of injection, the overall total length of the plume from the three wells is 8.2 miles. At 100 years, the plume has migrated no further. In fact it shrinks back a little to 7.9 miles in length.

Summary of Base and Alternate Cases

In summary, the modeling shows that there is adequate storage capacity in the reservoir and that the overlying formation(s) provide containment layers that prevent vertical movement of the CO₂. From an operation standpoint, several scenarios were considered and cases developed for detailed modeling and analysis, as described above.

Although one well could be adequate to handle CO₂ production, it may not be adequate to sustain secure injection operations (not exceed geologic constraints or permitted operating conditions). In addition, one well would not provide any backup capacity to the system. Three injection wells on two-mile spacing were established as the “base case” for the reservoir model. This design provided a good range of operating conditions and provided flexibility needed for optimizing injection. Two-well and four-well scenarios were evaluated as alternate cases or scenarios. Other factors considered for analysis and optimization included variations in reservoir conditions (e.g. porosity and permeability; pressure, fluid, and rock strength gradients), various well designs and configurations (e.g. well diameter, injection zones within the reservoir) and variations of the condition of the CO₂ (e.g. purity, temperature, well head pressure).

The study also determined the area has very low risk for potential does not have any potential leak paths of faults, wells, or mines that penetrate the caprock of the Eau Claire or the injection zone of the Mt. Simon in the 900 square mile study area. The lack of leak paths in the Eau Claire will keep the CO₂ confined to the to the injection zone.

The alternate case for reduced injection was considered in one modeling run. In this case, one injection well was “turned off” thereby reducing flow by one third and injecting the balance (evenly distributed) to the two remaining wells. The results are shown in Figure 8. As shown, the two wells were able to inject the reduced flow. Due to reduced interference, the area of the injected CO₂ varies slightly from the full injection. No other significant differences were observed in the modeling results. Further modeling and analysis would be needed to optimize injection. However, the results indicate that two wells could be adequate for injection.

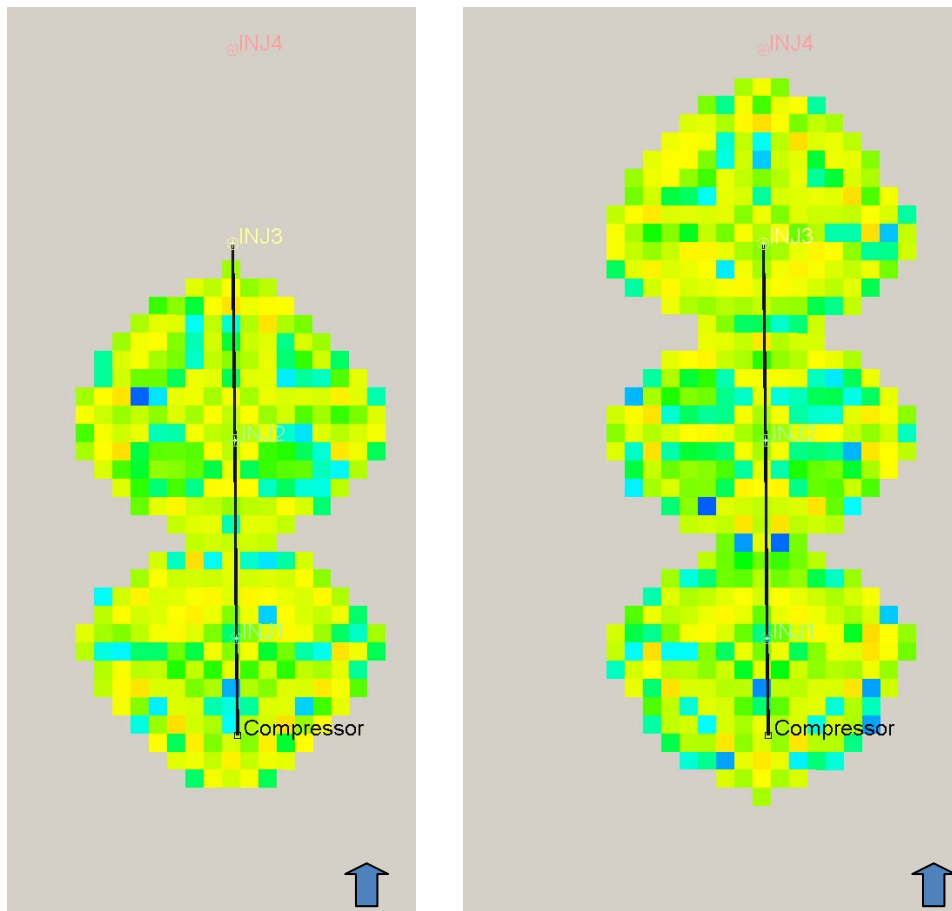

Figure 8. Comparison of reduced injection in two wells to full injection in three wells.

Project Monitoring

The monitoring, verification, and accounting (MVA) activities will be governed by the requirements of the class I non-hazardous UIC injection permit as well as the interim IRS 45Q guidance. Class VI UIC rules may also be used if and when they are promulgated.

The current design of the MVA program includes flow meters at each injection well to measure the volume of CO₂ that is injected into the formation. The field will have at least one deep observation well to monitor for CO₂ movement from the target formation. The field will also have shallow observation wells set in the fresh water aquifers above the injection field. The observation well will be designed to detect CO₂ leakage. A base line seismic survey as well as periodic seismic surveys may be completed to monitor movement of the injected CO₂. The timing and design of the seismic surveys will be adjusted to meet permit and regulatory requirements.

The injection wells will have periodic mechanical integrity testing to verify no CO₂ is leaking from the injection area through the well bore. Because the injection field does not have any other known faults, wells, or mines that penetrate the sealing caprock, no monitoring of such features is planned.

Three types of wells are anticipated for the project:

- Injection wells completed in the Mt. Simon sandstone, the storage reservoir (three wells are anticipated);
- Deep monitoring well completed in the St. Peter sandstone, a sandstone, a potential zone of low-salinity water and a known saline aquifer situated above the primary caprock seal;
- Shallow groundwater monitoring wells completed in the glacial outwash, the primary source of potable groundwater in the area; three wells are anticipated).

St. Peter Monitoring Well

The St. Peter sandstone is not developed as a potable, agricultural, or industrial water supply in the project area. However, data are available to indicate that it could meet the US EPA definition of the lowermost underground source of drinking water. Total dissolved solids (TDS) in the St. Peter are close to 10,000 parts per million (ppm) which is the limit set by the agency. For comparison, the injection reservoir salinity is expected to contain over 100,000 ppm TDS, several times the salinity of sea water.

As a result, site development and monitoring plans call for installation of one St. Peter monitoring well in association with one of the injection wells. The well will be equipped with a packer and downhole, real-time pressure gauge. Data will be transmitted to ground surface connected to the system control and data acquisition (SCADA) network. Additional information regarding the monitoring program is described in the "Monitoring" section.

In regards to construction assumptions, it is anticipated that the well can be installed and completed with two sets of carbon steel casing:

1. A 400 foot section of 9 5/8-inch surface casing set in a 12 1/4-inch borehole and
2. 5 1/2-inch production casing, approximately 3310 feet in length.

Standard metallurgy and installation methods are anticipated for well construction.

Shallow Groundwater Monitoring Wells

Three shallow groundwater monitoring wells will be completed in the glacial outwash, the primary source of potable groundwater in the area. The outwash zones can occur anywhere within the glacial sediments, which are approximately 100 feet thick in the area. Costs included here assume that each well will be constructed of Schedule 40 PVC and will be approximately 75 feet deep. Each well would be secured with a locking surface "stick up" to prevent tampering and with a minimum of three bollards to reduce the risk of surface damage due to vehicular traffic and vandalism.

Site monitoring can be considered to fall into two categories:

1. Verification and accounting
2. Security or leak detection

Real Time Monitoring

At the injection wells, the well head will be equipped to measure and record real time temperature, injection pressure, and flow rates to monitor system performance, for verification and accounting, and to optimize operations. Annular pressure will be monitored to evaluate leakage through the injection tubing or around the packer. Operating limits or range would be set to react to leaks that could develop in either the injection tubing or the production casing. We are proposing these limits at -5 psi to +50 psi. If there is a leak in the production casing, fluid would be lost from the annulus and a negative pressure would be observed. If there is a leak in the tubing, a positive pressure deflection would be observed. The operating range is set to reduce false

alarms resulting from other variations in operating conditions such as temperature changes.

Each St. Peter monitoring well will be equipped with down hole pressure gauges and (continuous) surface data recorders. The continuous record may be used to identify anomalous changes in subsurface conditions that could indicate vertical leakage through the caprock.

Periodic Monitoring

Formation Fluid Monitoring

The St. Peter wells will be accessed periodically to collect fluid samples. The proposed sampling and analysis schedule includes:

- One baseline (pre-injection)
- Annual through the first five years of injection (five rounds)
- Every five years through the end of injection (an additional five rounds assuming 30 years of injection)
- Every fifth year (two additional rounds) through the 10 year post-injection stabilization period.

Maintenance of the sample at formation pressure and analyses including gas-water ratio, ionic composition, pH, and analyses required for correction to account for mud filtrate. Sampling schedule may be adjusted based on the pressure and sampling results in conformity with applicable regulatory and permit requirements.

The three shallow monitoring wells will be monitored quarterly for one year, prior to start up of the injection system to establish baseline conditions, and then quarterly through the life of the injection phase and annually during the post injection stabilization period. This represents a total of 56 sampling events. The planned analyses include field pH measurements; laboratory analyses include major cations and anions, and select trace metals.

Seismic Monitoring

Seismic surveying is another method for monitoring the extent of the CO₂ in the subsurface. The principle underlying the technique is to generate a sonic signal and then measure their velocities as they travel down through the earth and back to sensors coupled with the ground surface. As CO₂ displaces brine, there would be expected a comparable change in the velocity of an acoustic signal through that zone. Using advance recording and processing techniques, repeat surveys can be completed to monitor the CO₂ over time.

Permitting Process

To legally inject CO₂ into the subsurface an owner/operator must get a Class I, non-hazardous underground injection control (UIC) permit from the State of Illinois. For CO₂ injection that is not related to petroleum production, the permit will be obtained through the Illinois Environmental Protection Agency. Required forms and supporting

documentation include IEPA permit application, IEPA-Form 4, to apply for an area permit for the Christian County Generation LLC Taylorville Energy Center. Collecting the necessary data, filling out the permit application, and applying for the permit are the first steps in the process for installing a CO₂ injection well at the TEC site.

Revised Case for Reduced Capture and Flow

A revised or alternate case considered 2,274,000 metric tons of CO₂ per year. Although this case was not modeled, the study results are extrapolated to suggest that two injection wells could be designed and optimized to handle this reduced volume. The CO₂ plume volume and area is also inferred to be proportionally reduced. So for this alternate case:

1. Injection well design is unchanged. Only the number of injection wells has been reduced
2. Two injection wells would be sufficient to handle the reduced flow
3. In the base case, the maximum CO₂ plume area as modeled is approximately 18 to 20 square miles; in the alternate case the modeled area is approximately 12 to 14 square miles.
4. Project monitoring methods would not change due to the reduced flow volume. The area included in periodic monitoring (e.g seismic survey would be reduced). Shallow groundwater (USDW) monitoring would be reduced proportionally.
5. St. Peter zone monitoring would be reduced proportionally.